

User Guide

Ocellus S100

High Performance GPS Surveillance & Tracking



Issue 1.0

Requests for wider use or release must be sought from:

Intellectual Property Division
QinetiQ Ltd
Cody Technology Park
Farnborough
Hampshire
GU14 0LX

Copyright © QinetiQ Ltd 2006

Administration Page

Record of Changes		
Issue	Date	Detail of Changes
1.0	31/03/06	

This document is supplied in confidence to the recipient for information purposes only and is not to be released outside the recipient's organisation or reproduced without the prior written permission of QinetiQ. Requests for permission for wider use or release should be made to Intellectual Property Department, QinetiQ.

Whilst QinetiQ has used reasonable care to ensure that the information in this User Guide is accurate, QinetiQ cannot guarantee that this User Guide is free from errors and omissions. Except to the extent set out in any contract between the user and QinetiQ relating to this product, QinetiQ makes no warranties, either expressed or implied, with respect to the information and specifications contained in this document.

List of Contents

1.	Introduction	4
2.	Ocellus Kit Contents	6
3.	Getting Started	9
4.	Operating Overview	15
5.	Application Examples	18
6.	Tracking Profile Recommendations	19
7.	Troubleshooting	22
8.	Status Indicator LEDs	24
9.	Specifications	25
10.	Safety Guidelines	26
11.	Glossary	27
12.	Warranty Information	28
13.	Qualified Service Agents	28
14.	Regulatory Information	28

1. Introduction

Congratulations on your purchase of the **Ocellus S100** high performance surveillance and tracking product. Ocellus represents a high technology, award winning approach to tracking, integrating our high sensitivity GPS positioning technology with the global GSM/GPRS standard in a compact, self-contained weather-resistant (IP56) case.

Ocellus S100 brings the benefits of high sensitivity GPS positioning to a range of tracking applications where conventional receivers fail, and supports a range of telematics applications through web-based service providers and value added resellers.

The high sensitivity of Ocellus S100 enables it to operate in challenging environments, where other GPS tracking units fail. Ocellus works inside a vehicle, in the glove box, under seats, in the trunk of a hatchback, and even on the underside of a vehicle. When fitted underneath a vehicle, Ocellus is able to use GPS signals reflected from the road surface.

Ocellus S100 is another high technology platform from QinetiQ, the Security and Defence experts.



Figure 1: Ocellus S100, With Multifunction Magnetic Mount

1.1. Ocellus S100 Versatility

Ocellus S100 enables a variety of tracking operations:

- **Surveillance** – track in difficult environments, including urban canyons, under trees, and even indoors.
- **Vehicle Tracking** – locate important vehicles, manage logistics and assist in stolen vehicle recovery.
- **Asset Tracking** – efficiently manage the location and re-deployment of valuable assets over long periods, and tracking of stolen items.
- **Cargo Tracking** – track valuable consignments in boxes, on pallets and in trucks, to improve efficiency or track shipments at risk of loss.

1.2. Ocellus S100 Overview

- **Highest Sensitivity GPS** – includes the QinetiQ Q20 GPS module for the most advanced, proven capability available today, with sensitivity of -183 dBW (acquisition) and -186 dBW (tracking) to provide the highest availability of position data, even in difficult tracking environments.
- **GSM / GPRS Global Standard** – tri-band GPRS integrated for economical operation using packet data, or where GPRS coverage is unavailable, the GSM Short Message Service (SMS) is used.
- **Very Long Operating Periods** - employs a unique power management architecture to minimise power consumption and deliver very long battery life.
- **Highly Configurable** – user-definable remote configuration enables your choice of tracking profile and reporting period.
- **Compact** – 133mm x 48mm x 24mm (5 ¼" x 1 7/8" x 1")
- **Easily installed** - internal antennas and rechargeable, high capacity lithium polymer battery mean no external connections are required, and the included multi-function magnetic mounting bracket enables rapid attachment to a variety of objects and surfaces.

Ocellus has three major components, which combine to provide its exceptional functionality:

- **Q20 HS GPS Receiver** - a high sensitivity GPS receiver that provides accurate position data in areas that conventional GPS cannot. This allows Ocellus to be positioned in places that are not feasible with previous generation GPS receivers, and to work in difficult tracking environments like urban canyons, under trees and indoors.
- **Activity Sensor** - detects motion and allows the unit to update its position if motion has been detected. This sensor permits the selection of tracking profiles that, for instance, request a position report only once a day unless it has detected movement, at which it wakes and reports its position. Or, if Ocellus knows that it has not moved since its last position report, it will not report the same position again, thus conserving power and saving money.
- **GSM / GPRS Modem** - the modem allows the broadcast of position and status data to the tracking server over global wireless networks, using GPRS packet data where network coverage permits, and defaulting to SMS messaging when GPRS is not available. Where no network coverage is available, Ocellus stores position data internally, and reports this history when it next logs on.

2. Ocellus Kit Contents

2.1. Unpacking

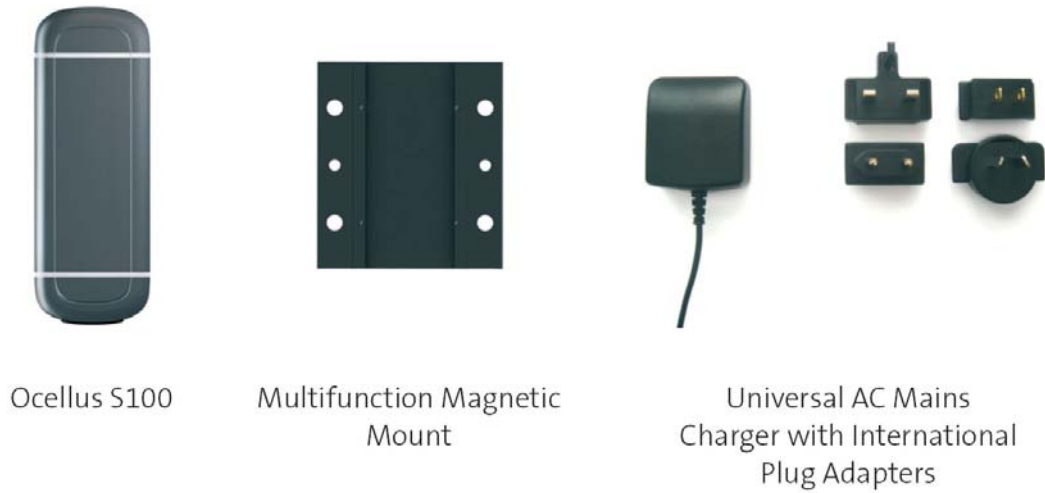

Figure 2: Ocellus S100 Kit Contents

(The contents of the kit are subject to change without notice)

2.2. Ocellus S100 Unit

The Ocellus unit is housed in a compact, weather-resistant (IP56) plastic enclosure. At one end of the unit there is a clear (white) rubber part covering the on/off switch and status indicator LEDs (the clear end - **Figure 3**). The opposite end (the black end - **Figure 4**) houses the charging port, which is sealed against water and dust ingress during use by the black charging port seal.



Figure 3: On/Off Switch and Status Indicator LED's

2.3. On/Off Switch

The On-Off switch is operated by pressing the clear rubber part at the point shown in Figure 3. You will feel a slight click when switching on or off.

Note: When powering Ocellus on, the LED indicators next to the switch will flash in the pattern [orange - > green - > off]. If you depress the switch, and no indication is shown, you have either just turned Ocellus off, or the battery requires charging.

2.4. Status Indicator LEDs

The four dots on the clear rubber part next to the switch show the position of the status indicator LEDs. These lights indicate the mode that Ocellus is in; for a full description of the modes and associated indicators, please refer to **Section 8**.

2.5. Charging Port

The charging port is situated under the lightning symbol at the black end. To access the charging port, peel the black rubber seal forwards. After charging, always ensure that the seal is fully inserted into the charging port, to prevent water and dust ingress.



Figure 4: Charging Socket and Charging Port Seal

2.6. Universal AC Mains Charger

The 5V 'universal' charger supplied with Ocellus is used to recharge the internal battery. The charger permits 110V – 240V, 50-60Hz AC input, and is supplied with Euro, UK, US and Australian adapters.

Note: Only use the charger supplied with Ocellus. Spare chargers may be ordered from your reseller if required.

2.7. Multifunction Magnetic Mount

Ocellus is supplied with a multi-function metal mounting bracket, including four powerful magnets to enable the user to attach Ocellus to ferrous metal objects. Alternatively, it can be cable-tied using the holes in the bracket.

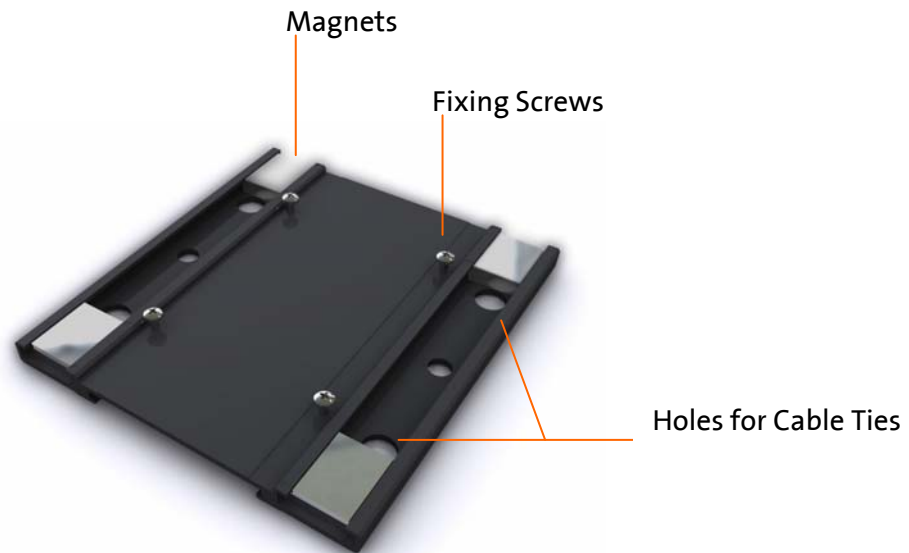

Figure 5: Multifunction Magnetic Mount

Note: The magnets in the multifunction magnetic mount are powerful. Take care when handling it in close proximity to ferrous objects, credit cards and other magnet-sensitive items.

2.8. SIM Card

The SIM card is pre-installed by your Ocellus reseller, and is sealed inside the unit. Should any physical problem arise with the SIM, or there is any requirement to change it, Ocellus should be returned to your reseller, who has the appropriate tools to carry out this procedure and ensure continuing weather-resistance of the case.

3. Getting Started

This section explains the steps required before Ocellus can be used: battery charging, configuration, enabling and establishing communication with the tracking service, and installation.

3.1. Charging the Battery

Ocellus is shipped with some charge in the battery, however it must be fully charged by the user before use. The charger is supplied with four mains plug adapters; select the one you require, and connect it to the charger. Peel back the black rubber charging port seal, insert the plug and turn the charger on at the mains. A full charge should take around 3-4 hours. The blue status indicator LED will illuminate to indicate charging; towards the end of the charging period, the blue light will dim, and then go off. When charging is complete, replace the charging port seal fully.

Note: Ocellus should be turned off while charging.



Figure 6: Charging the Battery

3.2. Enable Your Tracking Service

Before using Ocellus S100 for the first time, please take a note of the serial number and user password for your Ocellus S100, and the website address (URL) and log-in details of your tracking service, each of which will be required to access position information from Ocellus.

3.2.1. Serial Number

Each unit is identified by a unique serial number, shown on the compliance label on the back of Ocellus. This serial number is unique to each unit, and is required in the set-up procedure for your tracking service.

3.2.2. User Password

The user password is provided by the reseller. You will need this password to log on to your tracking service, access Ocellus position data, and to make changes to the configuration of your Ocellus.

3.2.3. Configuration

Ocellus can be configured to work exactly the way you need it to. When delivered to you, it has no tracking profile instructions built-in (unless you have arranged for your reseller to configure it for you). Therefore, before switching Ocellus on you must configure the parameters you require via the web interface of your tracking service. Instructions on

how to do that will be supplied by your tracking service provider. (See **Operating Overview – Section 4**, for guidance on configuration parameters.

3.3. Attaching the Multifunction Magnetic Mount

Use of the multifunction magnetic mount included with Ocellus is optional; Ocellus is designed to work with or without it. If your application requires the use of a fixing bracket, please follow the following instructions:

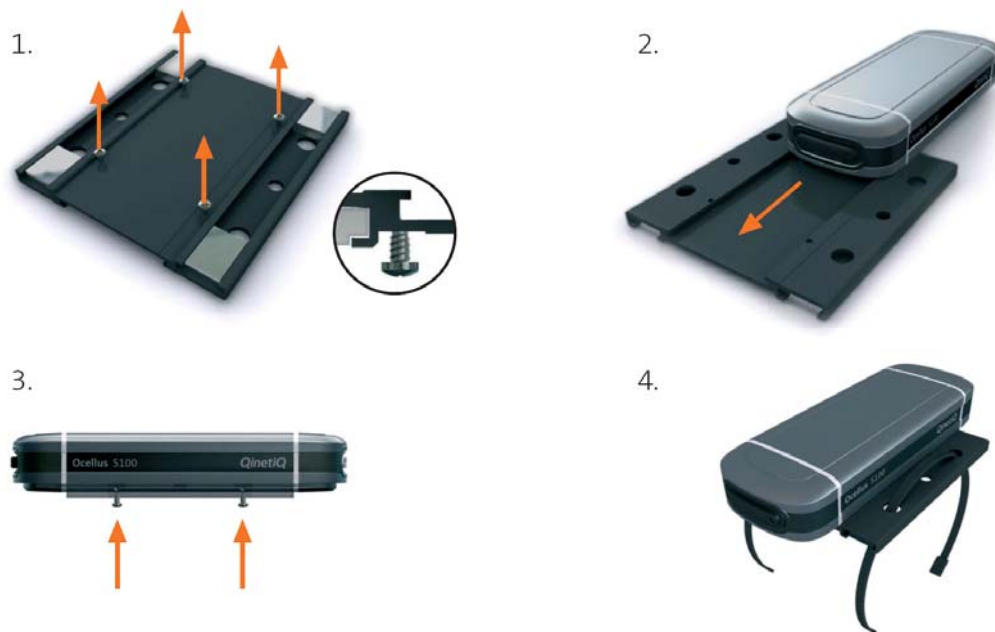

Figure 7: Attaching the Multifunction Mounting Bracket

1. Slacken the four small screws on the underside of the bracket, so the fixing channel is free of obstructions.
2. Slide Ocellus on to the bracket, so the 4 screws align with the 4 indents on the base of Ocellus.
3. Tighten the four screws against the bracket. They will bite into the Ocellus case a little to provide a secure fixing. Take care not to over-tighten the screws, as over-tightening could strip the thread in the bracket itself.
4. The magnets enable easy, rapid attachment to ferrous metal objects; additional fixing by removable cable ties is recommended where practical, or when fixing to non-ferrous objects.

Note: Care should be exercised if attaching Ocellus to the outside of a vehicle using the multifunction mounting bracket. Consider the position carefully, make sure the surface is flat, that the fixing is secure, the strength of the magnetic bond is not reduced by dirt or other surface coatings, and that it is not in a position where it could be knocked off. Provide additional fixings where possible; the use of removable cable ties is recommended. Screw-fixing or other permanent fixings requiring the use of a tool are not recommended. QinetiQ cannot be held responsible for loss or damage caused by incorrect fitting.

3.4. Initial Operation

3.4.1. Switch On



Figure 8: Switching On

Press the clear rubber part at the point shown in Figure 8. You will feel a slight click when switching on.

Note: When powering Ocellus on, the LED indicators next to the switch will flash in the pattern [orange - > green - > off]. If you depress the switch, and no indication is shown, you have either just turned Ocellus off, or the battery requires charging.

3.4.2. Logging On



Figure 9: Logging On

When Ocellus is first switched on, it will log on to the GSM network, and wait for the tracking profile instructions you have configured at your tracking service web interface. The orange indicator light will flash twice per second (2Hz) while it waits. As soon as it has received instructions, the green light will start to flash once per second (1Hz), indicating that it is acquiring GPS data from satellites.

Note: If at this point you have not yet configured your tracking profile, Ocellus will continue to wait for instructions, and the orange indicator LED will continue to flash twice per second (2Hz).

3.4.3. Obtaining a Position Fix



Figure 10: Obtaining a Position Fix

Ocellus needs to obtain its first GPS position fix. For this first time (and every subsequent time it is first powered on after being off) it is recommended that Ocellus is provided with a clear view of the sky for a minute or so. Watch the status indicator lights cycle through their mode indications - first green, then orange - until the orange light starts to flash very quickly (8Hz). Once this has happened, you know that Ocellus has:

- Obtained its first position fix (green LED flashing 8 times per second)
- Logged on to the GSM network, and reported the position (orange LED flashing 8 times per second)

You can now fit Ocellus in your preferred location. Ocellus will then power down into standby mode, only powering back up again in accordance with the tracking profile set at your tracking service.

Note: Allowing Ocellus a clear view of the sky for this first position fix is good practice; the fix will be faster and less power will be consumed. The system will work even if this is not done, however if the location of Ocellus is very obscured, it could take a long time to acquire its first fix, especially if it is in motion at the time.

3.5. Installation

The high sensitivity of Ocellus S100 enables it to operate in challenging environments, where other GPS tracking units fail. Ocellus works inside a vehicle, in the glove box, under seats, in the trunk of a hatchback, and even on the underside of a vehicle. When fitted underneath a vehicle, Ocellus is able to use GPS signals reflected from the road surface.

However, the installer should always provide it with the best view of the sky possible within their requirements, as this will ensure the best availability of position data, reduce power consumption and improve position accuracy in most cases.

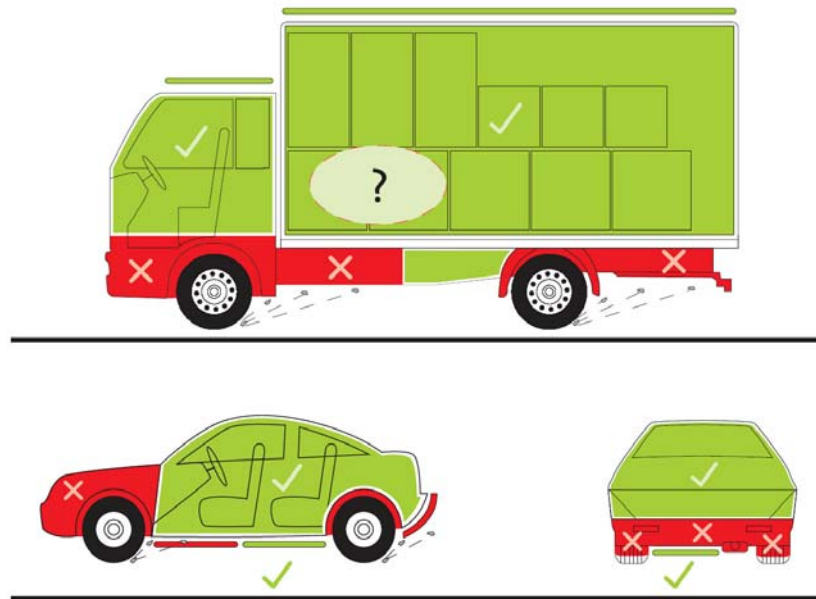

✓ Green - OK to install in green area. ✗ Red - Do not install in red area.

? - Experimentation required

Figure 11: Installation

Experimentation might be necessary. For instance, it has been shown that in most vehicles Ocellus will work very reliably on the dash, whereas in some vehicles with a metallised and/or heated front screen, the screen acts as an effective electrical shield, and can reduce the operational effectiveness of Ocellus.

Note: In some installations, Ocellus might be able to receive satellite signals and obtain a position fix, but be unable to log on to the GSM network and transmit that data, so as a general rule the installer should be aware that Ocellus will not be able to communicate in a position where a GSM mobile phone will not work.

3.6. Orientation

The GPS antenna is situated in the top (curved side) of the Ocellus case. It is recommended that, for best performance, Ocellus is installed with the antenna facing the direction that GPS signals are coming from. In most cases, this will be facing skyward of course; however when installed under a vehicle or other metal object, the strongest GPS signals will probably be reflecting off the ground, in which case installation upside-down is recommended (with the curved side facing downwards).



Figure 12: Antenna Orientation

With some experimentation with position, it should be possible to obtain very satisfactory performance. Should you experience problems with availability of position information, please refer to **Troubleshooting, Section 7**.

3.6.1. Environmental Conditions

Ocellus is designed for use on the inside or outside of a vehicle, and for general outdoor use in reasonable operating temperatures (see **Specifications, Section 9**). Ocellus should not be installed in areas subject to extreme temperatures, e.g. in the engine compartment or on to the exhaust system of a vehicle. Always install it in a position providing protection from impact (e.g. stones, kerbs, fork-lift trucks etc.) Do not mount it to the suspension of a vehicle. Ensure that the black rubber charging port seal is fully inserted at all times.

Note: Ocellus conforms to meet dust and water ingress protection standard IP56. This makes Ocellus suitable for most weather conditions it is likely to encounter, however this standard is only possible with the black rubber seal correctly inserted into the charging port. Ensure that the seal is fully inserted at all times.

4. Operating Overview

4.1. Configuration

Ocellus can be configured to work exactly the way you need it to. When delivered to you, it has no tracking profile instructions built-in (unless you have arranged for your reseller to configure it for you). Therefore, when you first switch it on, it will log on to the GSM network, and wait for instructions. Remote configuration is required via the web interface of your tracking service. Instructions on how to do that will be supplied by your tracking service provider.

4.2. Achieving and Reporting Its First Position Fix

Once Ocellus has received configuration instructions, the GPS receiver proceeds to acquire its first position fix (**Section 3.4.3**). Once this position fix has been obtained, it attempts to connect to the tracking server to report this position (and any other parameters requested), receive any modified tracking instructions from the server, and then returns to 'standby' mode, drawing negligible power from the battery.

In some cases, communication might be compromised by poor GSM signal strength, or lack of GPRS coverage, in which case Ocellus is designed to work in the following way:

- 1) It checks if it can access the GSM network (keeps trying for up to 120 seconds)
- 2) If it logs on to the GSM network, it first tries to communicate over GPRS
 - a. If it succeeds, it transmits over GPRS
 - b. If GPRS fails, it tries over SMS
 - c. If SMS fails, it will store the message
- 3) If it cannot log onto the GSM network it stores the message.
- 4) It will then power down into 'standby' mode until its next scheduled report, at which point it will follow the same procedure and relay any stored reports at the same time as its scheduled report.

4.2.1. Subsequent Periodic Position Reports

Ocellus stays in standby mode, and only powers on again at the intervals determined by the user via the tracking service web interface. After the configured time period, it powers up, achieves a position fix, and transmits it to the tracking server, along with any previous fixes it could not transmit according to 4.2 (above).

4.3. Data Bearers

4.3.1. GPRS

By default, Ocellus uses the GPRS service for transfer of messages to and from the tracking service. This is more economical than SMS, as messages are small and the GPRS service is usually charged by the volume of data sent, rather than the number of messages.

4.3.2. SMS

On occasions when the GPRS service is not available, messages can be sent using the Short Message Service (SMS) protocol over GSM. The information transferred is the same as that over GPRS, however the cost of each message will be charged at the rate for SMS charged by your tracking service provider. The user can select, at the tracking service web interface, whether or not Ocellus should default to SMS where GPRS is not available.

4.4. Message Storage

In the absence of GSM coverage, up to 4,000 messages will be stored in non-volatile memory and downloaded to your tracking service as soon as network coverage becomes available again.

4.5. Configuration Parameters

Your tracking service allows you to configure various Ocellus operational parameters via its web interface:

4.5.1. Additional Information Reported in Data Messages

Ocellus will report its position each time it reports to your tracking service, but it can also provide additional information to the user, if required:

- Altitude
- Speed
- Horizontal accuracy estimate
- Vertical accuracy estimate
- Battery capacity remaining (%)
- Time in motion since the last report (s)
- Reporting interval
- Initial credit of points to map over SMS (as agreed in your tracking service contract)
- Initial credit of points to map over GPRS (as agreed in your tracking service contract)
- Remaining credit of points to map over GPRS
- GPS time running (time taken to achieve the last GPS fix)

4.5.2. Activity Sensor Filter

Set the time (in seconds) over which the activity sensor should detect movement, to constitute 'motion' e.g. If the unit is knocked briefly, but then remains still, you can choose to have the unit report this, or not. This filter reduces unnecessary reporting.

4.5.3. Frequency of Reports When Alarm(s) Detected

Define the interval between reports when an alarm situation is reported. e.g. Geofencing; Ocellus can be configured to report an alarm if it moves outside a pre-configured area.

Note: At product launch, the 'Alarms' feature is not yet enabled.

4.5.4. Periodic Reports On/Off

Decide whether you want Ocellus to report its position periodically, or not.

Note: Because the Alarms feature (4.5.3) is not yet enabled, Periodic Reports must always be turned 'On'. It is therefore recommended that for applications where periodic reporting is not required (e.g. when reports on motion only are required) the user sets the periodic report frequency to 999 hours.

If Periodic Reports is set to 'Off', the user will receive no periodic reports, however they will receive no reports on activity either.

4.5.5. Reporting Interval Without Activity

Set how often (in hours, minutes or seconds) Ocellus should report its position whilst stationary.

Note: Only applies if Periodic Reports is enabled (see the note under 4.5.4 above)

4.5.6. Reporting Interval With Activity

Set how often (in hours, minutes or seconds) Ocellus should report its position when in motion.

Note: Only applies if Periodic Reports is enabled (see the note under 4.5.4 above)

4.5.7. Force GPS to Run When Stationary

If Ocellus detects no movement since the GPS module obtained the last position fix, the last position will still be considered valid, and a subsequent position fix will not be attempted, unless you force GPS to run when stationary. This prevents unnecessary power consumption.

Note: Preventing GPS running when stationary has benefits in battery life, however depending on your requirements, there is merit in allowing the GPS to run and obtain a fix every hour, thereby maintaining the validity of its last known information, refreshing Ephemeris and decreasing the time taken to obtain the next position fix. In these conditions, Ocellus will maintain HOT start conditions, and should have the following benefits:

- *Faster time to fix*
- *Improved percentage of valid fixes*
- *Maximised accuracy of Ocellus positional information*

Note: Only applies if Periodic Reports is enabled (see the note under 4.5.4 above)

5. Application Examples

The high sensitivity of Ocellus offers greater availability of position information than conventional GPS devices, and hence improved performance in urban areas and enclosed/covered areas. Applications include:

5.1. Surveillance

Ocellus may be used to track vehicles or other objects in environments considered difficult with other GPS receivers, including urban canyons, under trees, and indoors. The multifunction mounting bracket supplied facilitates simple and rapid deployment, if required.

5.2. Vehicle Tracking

Ocellus may be used for temporary or permanent tracking applications, to locate important vehicles, manage logistics, provide stolen vehicle tracking, and assist in stolen vehicle recovery. The long battery life of Ocellus allows it to be used for long periods without recharging, and without connection to the vehicle's power supply.

5.3. Asset Tracking

Assets of all kinds can be tracked using Ocellus S100, including construction machinery, caravans, garden machinery, computer equipment etc. Many valuable assets of this kind are stored for long periods without moving. The very long operating periods possible with Ocellus in standby mode make Ocellus ideal for tracking assets like these.

By setting the appropriate tracking profile, i.e. long intervals between periodic position reports (e.g. once a day) and instructing Ocellus to wake on movement only, the user can remotely monitor a valuable asset for months or even years in between battery charges.

5.4. Consignment Tracking

Vehicles containing valuable consignments usually carry GPS tracking capability, however the goods they are carrying are notoriously difficult to track and trace if stolen or misplaced.

Ocellus' high sensitivity, long battery life and compact size enable it to be packed in with consignments to provide position information from beginning to end of the journey, even indoors in many cases.

Note: In common with other Ocellus tracking applications, care should be taken to provide Ocellus with the best conditions to perform. Despite its high sensitivity, it is unlikely to function well if it is buried in the middle of a consignment or a sealed metal container, or if its view of the sky is otherwise severely compromised. Always experiment with such deployments, and define for yourself which positions give the best results. Also consider using multiple Ocellus units in very valuable consignments.

6. Tracking Profile Recommendations

6.1. 'Normal' Tracking Scenarios

The tracking task is considered 'normal' where Ocellus is fitted and used in a location with a direct view of the sky, for example:

- When fitted on the roof of a vehicle;
- When that vehicle is driven out in the open (not spending a high proportion of its time in a garage or multi-storey car park).

In this scenario Ocellus should work very reliably, achieving a very high success rate in achieving position fixes; the reported positions should be very accurate, and many hundreds (possibly thousands) of positions will be reported to the server per battery charge.

This scenario is ideal, and where possible it is recommended that Ocellus is used like this whenever possible.

6.1.1. Example Tracking Profiles for 'Normal' Tracking Scenarios

Profile 1: 'Normal' environment, Ocellus reports every 5 minutes (only when in motion):

- Motion filter sensor: **4s**
- Frequency of report when alarms detected: **Off** (*Note: Not yet enabled*)
- Periodic Reports: **On**
- Reporting Interval Without Motion: **999h**
- Reporting interval with motion: **5m**
- Force GPS to run when stationary: **Off**

Note: The interface to the functionality in this and the following tracking profile examples in Section 5 depends on the implementation at the tracking service web interface.

Profile 2: 'Normal' environment, Ocellus reports every hour (regardless of motion):

- Motion filter sensor: **4s**
- Frequency of report when alarms detected: **Off** (*Note: Not yet enabled*)
- Periodic Reports: **On**
- Reporting Interval Without Motion: **1h**
- Reporting interval with motion: **999h**
- Force GPS to run when stationary: **Off**

6.2. 'Challenging' Tracking Scenarios

The tracking task is considered 'challenging' where Ocellus is fitted and used in a location with an obstructed view of the sky, for example:

- When fitted inside or under a car;
- When frequently garaged or driven/parked in tunnels/covered car-parks/under bridges;
- Beneath a canopy (trees or buildings);

- Where the unit is buried under several layers of goods (e.g. when tracking a consignment)

In a ‘challenging’ tracking scenario, Ocellus will have to work harder to perform and this could be reflected in several aspects of performance:

- Some position fixes might not be determined when requested;
- Information might not be delivered over GPRS, or might not be delivered (at the time), in which case the information will be stored until Ocellus can gain access to the GSM network;
- The battery life will be shortened.

Where Ocellus is fitted in a ‘challenging’ environment, the following precautions are recommended (whenever possible):

- Turn Ocellus on and allow it to acquire a fix out in the open before stowing it in the “challenging” location (see **3.4.3 Obtaining a Position Fix**);
- Configure Ocellus with a minimum refresh rate of once an hour as suggested in Section 6.2.1, below.

6.2.1. Example Tracking Profiles for ‘Challenging’ Tracking Scenarios

Profile 3: ‘Challenging’ environment, Ocellus reports every 5 minutes when moving:

- Motion filter sensor: **4s**
- Frequency of report when alarms detected: **Off** *(Note: Alarms not yet enabled)*
- Periodic Reports: **On**
- Reporting Interval Without Motion: **59m** *(i.e. Less than one hour)*
- Reporting interval with motion: **5m**
- Force GPS to run when stationary: **On**

Profile 4: ‘Challenging’ environment, Ocellus reports every hour:

- Motion filter sensor: **4s**
- Frequency of report when alarms detected: **Off** *(Note: Alarms not yet enabled)*
- Periodic Reports: **On**
- Reporting Interval Without Motion: **59m**
- Reporting interval with motion: **999h**
- Force GPS to run when stationary: **On**

6.3. ‘Very Long Term’ Tracking Scenario

Ocellus can be used to ‘track’ a stationary asset, e.g. a caravan, trailer, construction plant or farming machinery that might remain stationary for weeks or even months at a time. When used to track such an object, the objective is to configure Ocellus to:

- Maximise battery life (do not force Ocellus to run GPS when stationary);
- Log on to the GSM network and report regularly (e.g. every 24 hours, to reassure the user that it is still in place and working, and to receive any updated tracking profile settings);
- Provide a higher frequency of position reports if it is moved.

6.3.1. Example Tracking Profile for 'Very Long Term' Tracking Scenario

Profile 5: 'Very long term' requirement, Ocellus reports every 24 hours, or every 2 minutes when it moves:

- Motion filter sensor: **4s**
- Frequency of report when alarms detected: **Off** (*Note: Not yet enabled*)
- Periodic Reports: **On**
- Reporting Interval Without Motion: **24h**
- Reporting interval with motion: **2m**
- Force GPS to run when stationary: **Off**

Note: When configured in this way, Ocellus will COLD start whenever an event is triggered. Therefore the installer should ensure that for 'very long term' tracking scenarios, Ocellus is placed in an 'normal' location, where it has a good view of the sky.

6.4. Battery Life Guidelines

Ocellus will provide a minimum of 300 position fixes on one battery charge. In many cases, this figure will be easily exceeded, but this is dependent on the tracking profile selected, and its installation conditions. Where Ocellus has a very restricted view of the sky, it will use more power to achieve a fix than where its view is clear. Similarly, if it is configured with a tracking profile allowing limited time in standby mode, it will consume power more quickly than when its tracking profile allows long periods in standby. The quality of GSM coverage will also have an effect on battery life. The information below is provided for guidance:

- Number of positions reported on one battery charge: 300 to 1000
- Battery life:
 - In 'Standby' mode: >1 year *
 - Reporting once per day: Up to 1 year *
 - Reporting every 5 mins: 24 hours *

** Depending on installation conditions*

Note: Ocellus can be configured to provide a battery condition report in every message sent to your tracking service, enabling easy remote monitoring.

6.5. Related Information

Up to date user guides, updated FAQ's and other useful information related to Ocellus may be downloaded from www.QinetiQ.com/gps

Information relating to your web-based tracking service should be obtained directly from your tracking service provider.

6.6. Technical Assistance

In the event that you require technical assistance relating to Ocellus, please refer firstly to **Troubleshooting - Section 7**. If you still cannot resolve the problem, please contact your reseller, who is able to help you overcome most of the technical problems that might arise when operating Ocellus. If they cannot resolve the problem, they will refer it to QinetiQ or the tracking service provider, depending on the nature of the issue.

7. Troubleshooting

7.1. No Position Data Available On the Tracking Server

Possible Causes:

- **Ocellus is powered off:**
 - Check whether Ocellus is displaying any status indicator LED activity. If not, power off and power on again (checking for the powering on sequence (see **Section 8**))
- **Ocellus is set to a tracking profile that only provides one fix every day, and it has not yet provided a position:**
 - Reconfigure the tracking settings to provide its position at the frequency you require, and either wait for Ocellus to power up according to its previous tracking profile settings, or power it off then on again, to make it report to the server and obtain its new settings.
- **Ocellus is set to a tracking profile where 'Periodic Reports' is set to 'Off'**
 - Set 'Periodic Reports' to 'On' and select a reporting frequency that suits your application.
- **Ocellus is stationary:**
 - In this case its activity sensor has kept it in standby mode to conserve power and prevent multiple reports of the same position.
- **GSM reception is poor:**
 - Either it is in an area with poor GSM reception, or its reception is obscured locally by its location (in a metal box / underground etc.), thus preventing it from reporting its position. In this case, the orange LED is likely to be flashing once per second for a long time (>20s). Check where Ocellus is positioned and rectify.
- **Ocellus could not obtain its first fix.** (Red indicator LED is on permanently or the green LED is flashing at 1Hz for a long time (>2min)):
 - Provide Ocellus with a clear view of the sky for 1-2 minutes (until the green light flashes rapidly (8 Hz) before stowing it in the position you require.
- **The configuration has not been set by the reseller.** (Every 1 minute the orange light comes on and flashes briefly at 1Hz):
 - Return the unit to the reseller.
- **The SIM card is not fitted, or there is a fault with the SIM card.** (The red LED is on solidly):
 - Return the unit to the reseller.
- **The battery needs charging:**
 - Check whether you received a low battery notification from Ocellus via the tracking service. Press and release the On/Off button twice while referring to **Section 8**. If no indicator LED's illuminate, recharge the battery.
- **Ocellus has been deliberately disabled, or physically damaged:**
 - Check its condition.

7.2. Ocellus has been charging for many hours but the charging LED is still on (or the battery charging indicator LED does not illuminate):

- The battery has entered 'protection mode' because it was left running for many hours after it announced that the battery charge was at a critical level.
 - Unplug the charger
 - Press the on/off switch once to turn Ocellus off
 - Reconnect the charger

Note: Ocellus can be configured to report the % battery capacity remaining with every report, thereby providing warning of the battery condition (See Section 4.5.1 – Additional Information Reported in Data Messages)

7.3. Ocellus Keeps Reporting the Same Position, Even When the Unit is Moving

Possible Causes:

- GPS reception is poor – Ocellus is re-reporting its last known position; move it to where it is able to acquire signals from satellites

8. Status Indicator LEDs

Ocellus S100 is equipped with four LEDs that indicate its operational status. From left to right these are GREEN, RED, ORANGE and BLUE.



Figure 13 – Status Indicator LEDs

	GREEN	RED	ORANGE	BLUE	COMBINED ORANGE->GREEN->OFF
FUNCTION	GPS	ERRORS	GSM	BATTERY CHARGING	POWERING ON
OFF	GPS off	No Error	GSM off	Not charging, or battery fully charged	-
ON (SOLID)	-	Failure to fix, or GPS interface error (system still functioning, Ocellus should correct this condition without intervention)	Communicating over GPRS	Charging	-
ON (DIM)	-	-	-	Trickle charging	-
FLASHING 1Hz	Acquiring data	Battery requires charging	Logging on	-	Powering on (flash once only)
FLASHING 8Hz	Acquired GPS 3D fix	-	Communicating by SMS	-	-

Table 1 – Status Indicator LEDs

9. Specifications

GPS PERFORMANCE (12 CHANNEL)	RF Reception Sensitivity:	-186 dBW tracking -183 dBW acquisition
	Signal Acquisition	Hot: <1 sec Warm: <38 sec Cold: <45 sec
	Re-acquisition	<0.5 sec
ACCURACY	Position: Outdoor/Indoor Velocity (Outdoor):	<5m / <50m typical <0.05ms-1
GSM/GPRS PERFORMANCE	Tri-band GSM/GPRS: GPRS Class 10: Point-to-point SMS: Text and PDU mode SMS GSM phase 2/2+ compliant Output Power - GSM900 Output Power - GSM1800/1900	900/1800/1900 MHz Max 85.6 kbps MO and MT 2W 1W
POSITION FIXES STORED	(In Internal Memory)	Up to 4,000 positions
PHYSICAL	Ocellus S100 Dimensions: Weight: Ocellus Case: Multifunction Mount: Multifunction Mount Dimns:	133mm (L) x 48mm (W) x 24mm (H) 141g All plastic Anodised aluminium, incorporating 4 magnets 90mm (L) x 80mm (W) x 6mm (H)
ENVIRONMENTAL	Operating / Storage Temp: Max Velocity / Altitude: Max Acceleration / Jerk: Dust / Water Ingress Protection:	-20°C to + 60°C / -45°C to +85°C 515ms-1 / 18,000m Complies with DEF STAN 00-35 (Part 3) IP56
POWER	Internal Battery Charging Requirements: Mains Charger:	Lithium Polymer 5V, 600mA 5V, 1000mA output, 110 – 240V, 50-60Hz AC input, supplied with Euro, UK, US and Australian adapters
POWER EFFICIENCY	Number of Positions Reported (on one battery charge) Battery Life - In 'Standby' Mode: - Reporting Once per Day - Reporting Every 5 Mins.	300 to 1000 >1 year * Up to 1 year * 24 hours * <i>* Depending on installation conditions</i>
ALARMS	Movement, Battery Low, Geo-Fencing (<i>future upgrade</i>)	
INTERFACES	On/Off Switch: Status Indicator LEDs x 4: Battery Charging Port: Web Interface:	Activates / de-activates the unit Status monitoring Enables battery charging Enables remote monitoring and configuration of Ocellus over the web
ACCESSORIES	5V Universal Mains Charger: Multifunction Mount Assembly:	Part No. QP0020-248 Part No. QP0020-100

Table 2: Specifications

10. Safety Guidelines

10.1. General Recommendations

- Do not install your product in areas subject to extreme temperatures, e.g. in the engine compartment or on to the exhaust system of a vehicle.
- Always install your product in a position providing protection from impact (e.g. stones, kerbs, fork-lift trucks etc.)
- Do not install your product in the area above the air bag in a vehicle.
- Do not expose your product to open flames or other strong sources of heat.
- Do not drop, throw or try to bend your product.
- Do not paint your product.
- Do not attempt to disassemble your product. (Only QinetiQ and authorised resellers should perform service on Ocellus, and any attempt to do so will invalidate the warranty).
- Take care when handling the multifunction magnetic mount in close proximity to ferrous objects, credit cards and other magnet-sensitive items.

10.2. Universal AC Power Supply / Charger Unit

Make sure the cord is positioned so that it will not be subjected to damage or stress. To reduce the risk of electric shock, unplug the unit from any power source before attempting to clean it. The AC power adapter must not be used outdoors or in damp areas. Never alter the cord or plug.

10.3. Prohibited Areas

Ocellus contains a GSM radio transmitter, therefore its use is subject to the same rules as for a mobile phone. Examples of areas where its use may be prohibited are:

- Hospitals
- Aircraft
- Military sites
- Other radio-prohibited areas, e.g. those with explosive atmospheres

10.4. Personal Medical Devices

The manufacturers of some medical devices, such as heart pacemakers and other implanted equipment, recommend that a minimum separation distance of 150mm (6") should be maintained between a mobile phone and the medical device. As Ocellus contains a GSM transmitter, it is recommended that the user avoids placing Ocellus over the pacemaker, e.g. in your breast pocket. If you have any reason to suspect that interference is taking place, turn Ocellus off immediately.

11. Glossary

Almanac	Almanac data is broadcast by all 24 GPS satellites, and describes coarse orbital parameters for all satellites. Almanac data is valid for several months.
Cold Start	A Cold Start is defined as starting the satellite data acquisition process using no previous GPS Almanac, Ephemeris, time or position data.
Ephemeris	Ephemeris is precise orbital and clock correction data for each satellite, and is necessary for precise positioning. Each satellite broadcasts only its own Ephemeris data every 30 seconds, which is valid for at least an hour.
Fix	The generation of a single GPS based position solution. This may include the time taken to acquire sufficient satellite signals (usually from four satellites), to demodulate ephemeris data from the navigation data stream, and to calculate a position solution.
GPRS	General Packet Radio Service – a protocol that provides a packet based data transfer service, based on the existing GSM protocol and running over the GSM network.
GPS	Global Positioning System.
GSM	Global System for Mobile Communications - a radio standard that allows interoperability between different wireless networks
Hot Start	A Hot Start is defined as starting the satellite data acquisition process using a valid Almanac, valid Ephemeris, known position to 1km accuracy and known time to 1ms accuracy. If Ocellus carries out a position fix within 30 minutes of the last one, Ephemeris data is less than 30 minutes old, and the fix will be obtained very quickly since Ocellus does not have to collect new Ephemeris data.
HS GPS	High Sensitivity GPS
Standby	The minimal power consumption mode that Ocellus goes into between position fixes.
IP56	Ingress Protection Rating 56 - a standard of dust- and water-resistance, meaning that Ocellus is protected against dust and strong jets of water.
LED	Light emitting diode – the type of low power indicator lights used in Ocellus
Sensitivity	The smallest RF signal received that can be used to provide a useful output. In the case of a GPS receiver this is the lowest signal level that can be used to contribute to a position solution.
SIM	Subscriber Identity Module - contains information about the identity of a subscriber, the mobile phone number, and authentication and service information.
SMS	Short Message Service - a protocol for transmitting short messages to and from wireless devices across networks such as GSM.
Tracking Profile	The Tracking Profile is the set of Ocellus tracking instructions set by the user, e.g. frequency of periodic reports, whether to report on detecting motion etc.
Warm Start	A Warm Start is defined as starting the satellite data acquisition process with a valid Almanac, and known time. Ephemeris data must be obtained, however this process is quicker than a Cold Start, and is usually possible with Ocellus even in difficult environments.

12. Warranty Information

The Warranty Information provided in this documentation applies to Ocellus S100 products sold to end-users by a QinetiQ authorised reseller:

If you have any difficulty using this QinetiQ product, please first consult the Quick Start Guide and the User Guide (available at www.QinetiQ.com/gps) to check that you are using the product correctly, and then consult your reseller for guidance on correcting the problem that you are experiencing. Any warranty claim must be made via the QinetiQ authorised reseller who supplied the product.

13. Qualified Service Agents

Ocellus contains no user-serviceable or replaceable parts. In the event of any repair or replacement being required (whether inside or outside the warranty terms above) please return the unit to the reseller from whom you purchased it.

14. Regulatory Information

14.1. Disposal

14.1.1. WEEE



The crossed out wheeled bin logo on the compliance label indicates that this product should not be treated as household waste. Instead it should be handed over to the applicable collection point for the recycling of electrical and electronic equipment. For more details on available collection facilities, please contact your local government office, your household waste disposal service or the reseller where you purchased this product.

This information only applies to customers in the European Union, according to Directive 2002/97/EC of the European Parliament and of the Council of 27 January 2003 on Waste Electrical and Electronic Equipment (WEEE), and legislation transposing and implementing it into the various national legal systems.

For other countries, please contact your local government to investigate the possibility of recycling your product.

14.1.2. Battery Disposal

Ocellus contains a lithium polymer rechargeable battery. This battery must be disposed of properly. Do not pierce, disassemble or incinerate the battery.

- **Warning!** May explode if disposed of in fire.

14.2. Regulatory Approvals

14.2.1. CE



Ocellus S100 complies with the essential requirements of the R&TTE Directive 1999/5/EC of the European Parliament and of the Council of 9 March 1999 as stated by the EC Declaration of Conformity, with requirements covering the EMC directive 89/336/EEC, and Low Voltage Directive 73/23/EEC.